

# SC - 鉄筋コンクリートU形側溝

## ■ 形状図

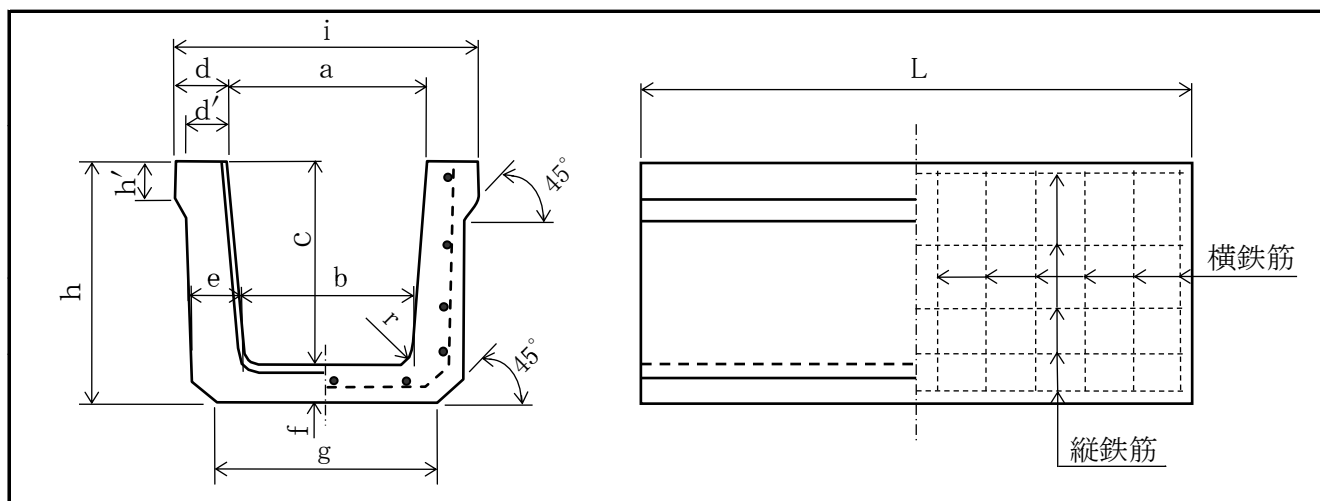

## ■ 寸法表

呼び名	寸 法 (mm)													
	a	b	c	d	d'	e	f	g	h	h'	i	r	L	
180	180	160	180	50	35	40	40	180	220	40	280	50	1000	2000
240	240	220	240	60	45	50	50	240	290	35	360	50	1000	2000
300A	300	260	240	70	50	60	60	310	300	40	440	50	1000	2000
300B	300	260	300	70	50	60	60	300	360	50	440	50	1000	2000
300C	300	260	360	70	50	60	65	300	425	50	440	50	1000	2000
360B	360	310	360	70	50	65	65	360	425	55	500	50	1000	2005
450	450	400	450	75	55	70	70	430	520	60	600	70	1000	2000
600	600	540	600	95	70	80	80	600	680	70	790	70	1000	2000
700	700	600	700	110	80	100	100	700	800	100	920	70	1000	2000
800	800	700	800	110	80	100	100	800	900	100	1020	70	1000	2000
900	900	800	900	120	90	110	110	900	1010	110	1140	70	1000	2000
1000	1000	900	1000	130	90	110	110	1000	1110	110	1260	70	1000	2000
許容差	±3	±3	±3	±3	—	±3	±3	—	—	—	—	—	±6	±6

## ■ 配筋表及び製品参考質量

呼び名	配 筋					製品参考質量 (kg)	
	縦鉄筋		横鉄筋			L=1000	L=2000
	径(mm)	数量(本)	径(mm)	数量(本)			
				L=1000	L=2000		
180	3.20	7	3.20	8	16	55	110
240	3.20	9	3.20	8	16	90	180
300A	3.20	9	4.00	8	16	118	236
300B	3.20	9	4.00	8	16	134	268
300C	3.20	11	4.00	12	24	153	306
360B	4.00	11	4.00	13	26	168	336
450	4.00	11	5.00	13	26	227	454
600	5.00	17	5.00	17	34	343	686
700	D6	12	D10	6	12	510	1020
800	D6	14	D10	6	12	580	1160
900	D6	14	D10	7	14	709	1418
1000	D6	17	D10	8	16	806	1612